

# HiDM5 (All-Black)

ALL-BLACK HIGH DENSITY MONO PERC MODULE

380 W ~ 415 W

CS1Y-380 | 385 | 390 | 395 | 400 | 405 | 410 | 415MS

## MORE POWER



Aesthetically pleasing design blends into your roof



Maximize the light absorption area, module efficiency up to 20.6 %



Low temperature coefficient (Pmax): -0.36 % / °C



Better shading tolerance

## MORE RELIABLE



Lower internal current, lower hot spot temperature



Minimizes micro-crack impacts



Heavy snow load up to 5400 Pa, wind load up to 2400 Pa\*



enhanced product warranty on materials and workmanship\*



linear power output warranty\*

\*According to the applicable Canadian Solar Limited Warranty Statement.

## MANAGEMENT SYSTEM CERTIFICATES\*

ISO 9001: 2015 / Quality management system

ISO 14001: 2015 / Standards for environmental management system

ISO 45001: 2018 / International standards for occupational health & safety

## PRODUCT CERTIFICATES\*

\* The specific certificates applicable to different module types and markets will vary, and therefore not all of the certifications listed herein will simultaneously apply to the products you order or use. Please contact your local Canadian Solar sales representative to confirm the specific certificates available for your Product and applicable in the regions in which the products will be used.

**CSI Solar Co., Ltd.** is committed to providing high quality solar products, solar system solutions and services to customers around the world. Canadian Solar was recognized as the No. 1 module supplier for quality and performance/price ratio in the IHS Module Customer Insight Survey, and is a leading PV project developer and manufacturer of solar modules, with over 50 GW deployed around the world since 2001.

\* For detailed information, please refer to Installation Manual.

## ENGINEERING DRAWING (mm)

Rear View

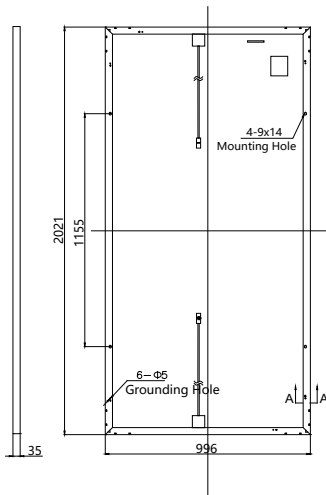

Frame Cross Section A-A

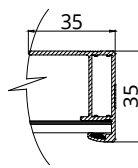

Mounting Hole

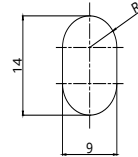

## CS1Y-400MS / I-V CURVES

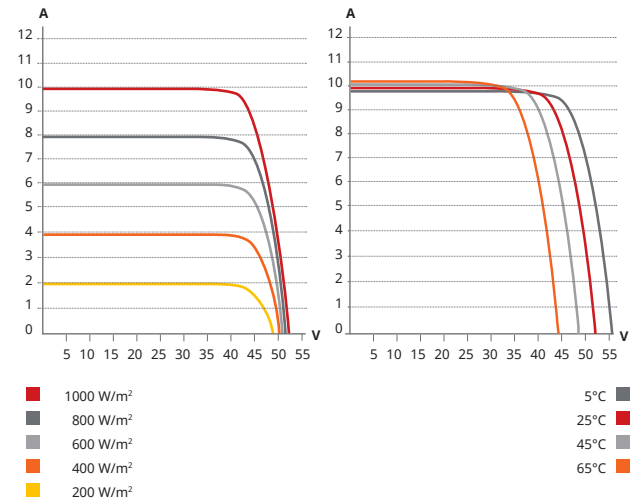

## ELECTRICAL DATA | STC\*

CS1Y	380MS	385MS	390MS	395MS	400MS	405MS
Nominal Max. Power (Pmax)	380 W	385 W	390 W	395 W	400 W	405 W
Opt. Operating Voltage (Vmp)	42.7 V	42.9 V	43.1 V	43.3 V	43.5 V	43.7 V
Opt. Operating Current (Imp)	8.89 A	8.97 A	9.05 A	9.13 A	9.20 A	9.27 A
Open Circuit Voltage (Voc)	51.5 V	51.7 V	51.9 V	52.1 V	52.3 V	52.5 V
Short Circuit Current (Isc)	9.74 A	9.78 A	9.82 A	9.86 A	9.90 A	9.94 A
Module Efficiency	18.9%	19.1%	19.4%	19.6%	19.9%	20.1%
Operating Temperature	-40°C ~ +85°C					
Max. System Voltage	1000V (IEC/UL)					
Module Fire Performance	TYPE 1 (UL 1703) or CLASS C (IEC 61730)					
Max. Series Fuse Rating	16 A					
Application Classification	Class A					
Power Tolerance	0 ~ + 10 W					

\* Under Standard Test Conditions (STC) of irradiance of 1000 W/m<sup>2</sup>, spectrum AM 1.5 and cell temperature of 25°C.

## MECHANICAL DATA

Specification	Data
Cell Type	Mono-crystalline
Dimensions	2021 × 996 × 35 mm (79.6 × 39.2 × 1.38 in)
Weight	23.6 kg (52.0 lbs)
Front Cover	3.2 mm tempered glass
Frame	Anodized aluminium alloy
J-Box	IP68, 3 bypass diodes
Cable	4.0 mm <sup>2</sup> (IEC), 12 AWG (UL)
Cable Length (Including Connector)	740 mm (29.1 in) *
Connector	T4 series or MC4
Per Pallet	30 pieces
Per Container (40' HQ)	660 pieces

\* Adjacent two modules (portrait: left and right modules, landscape: up and down modules) need to be rotated 180 degrees.

## ELECTRICAL DATA | NMOT\*

CS1Y	380MS	385MS	390MS	395MS	400MS	405MS
Nominal Max. Power (Pmax)	282 W	286 W	289 W	293 W	297 W	300 W
Opt. Operating Voltage (Vmp)	39.5 V	39.7 V	39.9 V	40.1 V	40.3 V	40.4 V
Opt. Operating Current (Imp)	7.13 A	7.19 A	7.25 A	7.31 A	7.37 A	7.43 A
Open Circuit Voltage (Voc)	48.2 V	48.4 V	48.6 V	48.8 V	49.0 V	49.2 V
Short Circuit Current (Isc)	7.86 A	7.89 A	7.92 A	7.96 A	7.99 A	8.02 A

\* Under Nominal Module Operating Temperature (NMOT), irradiance of 800 W/m<sup>2</sup>, spectrum AM 1.5, ambient temperature 20°C, wind speed 1 m/s.

## TEMPERATURE CHARACTERISTICS

Specification	Data
Temperature Coefficient (Pmax)	-0.36 % / °C
Temperature Coefficient (Voc)	-0.28 % / °C
Temperature Coefficient (Isc)	0.05 % / °C
Nominal Module Operating Temperature	43 ± 3°C

## PARTNER SECTION

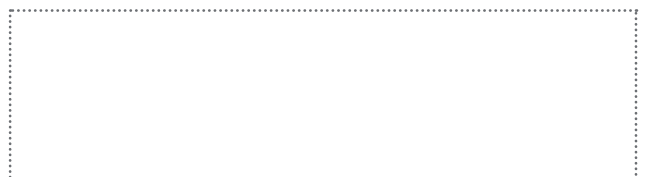

\* The specifications and key features contained in this datasheet may deviate slightly from our actual products due to the on-going innovation and product enhancement. CSI Solar Co., Ltd. reserves the right to make necessary adjustment to the information described herein at any time without further notice. Please be kindly advised that PV modules should be handled and installed by qualified people who have professional skills and please carefully read the safety and installation instructions before using our PV modules.

**CSI Solar Co., Ltd.**

199 Lushan Road, SND, Suzhou, Jiangsu, China, 215129, www.csisolar.com, support@csisolar.com

## ENGINEERING DRAWING (mm)

Rear View

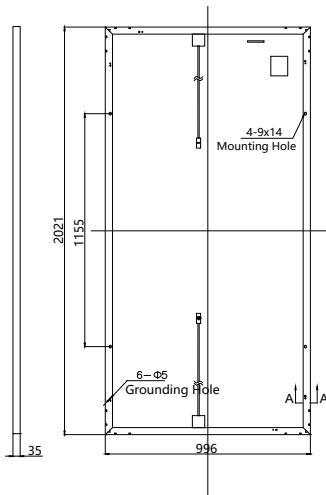

Frame Cross Section A-A

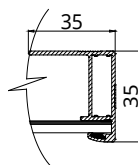

Mounting Hole

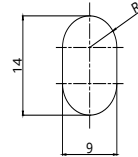

## CS1Y-400MS / I-V CURVES

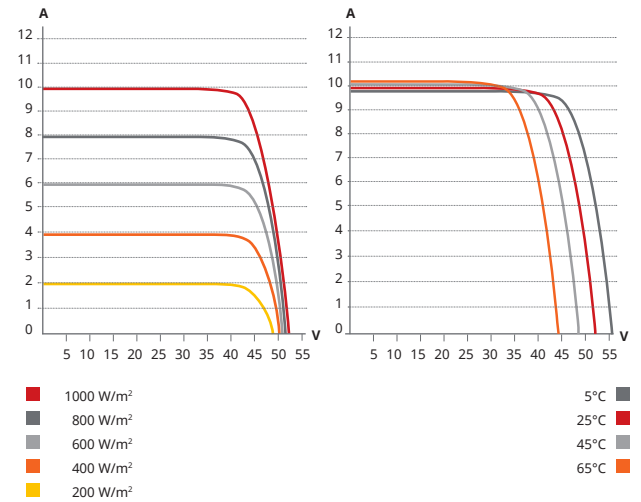

## ELECTRICAL DATA | STC\*

CS1Y	410MS	415MS
Nominal Max. Power (Pmax)	410 W	415 W
Opt. Operating Voltage (Vmp)	43.8 V	44.0 V
Opt. Operating Current (Imp)	9.37 A	9.44 A
Open Circuit Voltage (Voc)	52.7 V	52.8 V
Short Circuit Current (Isc)	9.98 A	10.02 A
Module Efficiency	20.4%	20.6%
Operating Temperature	-40°C ~ +85°C	
Max. System Voltage	1000V (IEC/UL)	
Module Fire Performance	TYPE 1 (UL 1703) or CLASS C (IEC 61730)	
Max. Series Fuse Rating	16 A	
Application Classification	Class A	
Power Tolerance	0 ~ + 10 W	

\* Under Standard Test Conditions (STC) of irradiance of 1000 W/m<sup>2</sup>, spectrum AM 1.5 and cell temperature of 25°C.

## ELECTRICAL DATA | NMOT\*

CS1Y	410MS	415MS
Nominal Max. Power (Pmax)	304 W	308 W
Opt. Operating Voltage (Vmp)	40.5 V	40.7 V
Opt. Operating Current (Imp)	7.50 A	7.56 A
Open Circuit Voltage (Voc)	49.4 V	49.4 V
Short Circuit Current (Isc)	8.05 A	8.08 A

\* Under Nominal Module Operating Temperature (NMOT), irradiance of 800 W/m<sup>2</sup> spectrum AM 1.5, ambient temperature 20°C, wind speed 1 m/s.

## MECHANICAL DATA

Specification	Data
Cell Type	Mono-crystalline
Dimensions	2021 × 996 × 35 mm (79.6 × 39.2 × 1.38 in)
Weight	23.6 kg (52.0 lbs)
Front Cover	3.2 mm tempered glass
Frame	Anodized aluminium alloy
J-Box	IP68, 3 bypass diodes
Cable	4.0 mm <sup>2</sup> (IEC), 12 AWG (UL)
Cable Length (Including Connector)	740 mm (29.1 in) *
Connector	T4 series or MC4
Per Pallet	30 pieces
Per Container (40' HQ)	660 pieces

\* Adjacent two modules (portrait: left and right modules, landscape: up and down modules) need to be rotated 180 degrees.

## TEMPERATURE CHARACTERISTICS

Specification	Data
Temperature Coefficient (Pmax)	-0.36 % / °C
Temperature Coefficient (Voc)	-0.28 % / °C
Temperature Coefficient (Isc)	0.05 % / °C
Nominal Module Operating Temperature	43 ± 3°C

## PARTNER SECTION

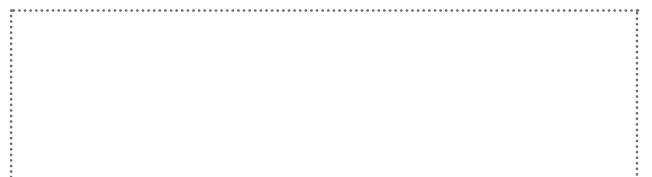

\* The specifications and key features contained in this datasheet may deviate slightly from our actual products due to the on-going innovation and product enhancement. CSI Solar Co., Ltd. reserves the right to make necessary adjustment to the information described herein at any time without further notice. Please be kindly advised that PV modules should be handled and installed by qualified people who have professional skills and please carefully read the safety and installation instructions before using our PV modules.

**CSI Solar Co., Ltd.**

199 Lushan Road, SND, Suzhou, Jiangsu, China, 215129, [www.csisolar.com](http://www.csisolar.com), [support@csisolar.com](mailto:support@csisolar.com)